

NOTES: **** LUMABAR LIGHTING****
IN EACH COMPARTMENT
(MAGNETIC SWITCH)

**** COMPARTMENTS INTERIOR:**
ZOLATONE 20-72 **

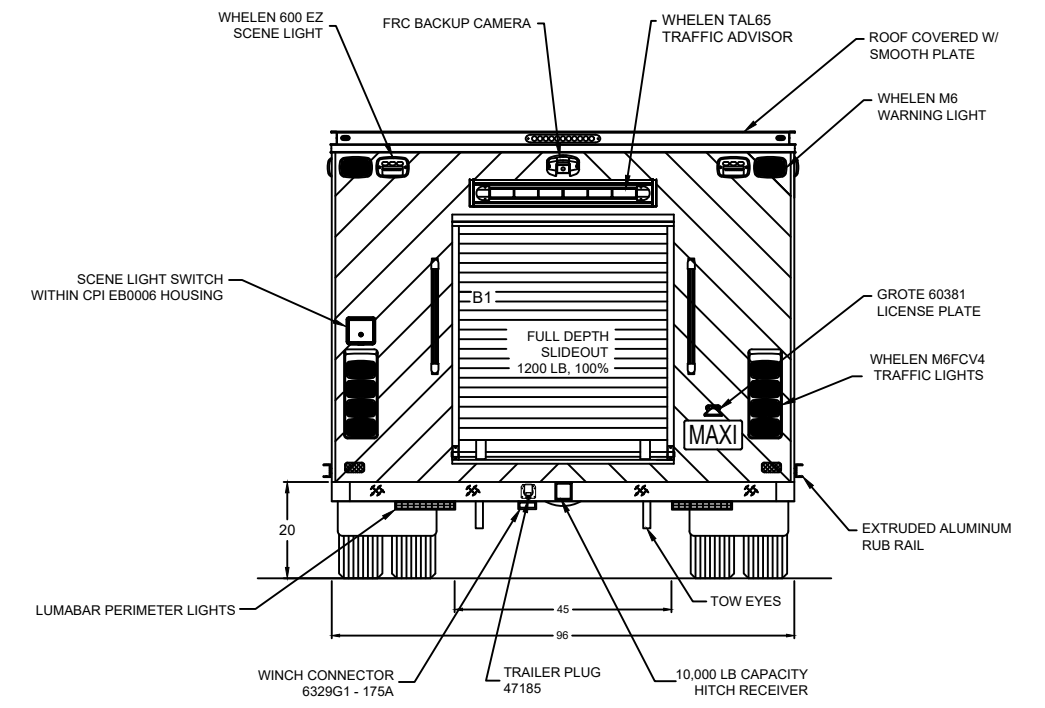
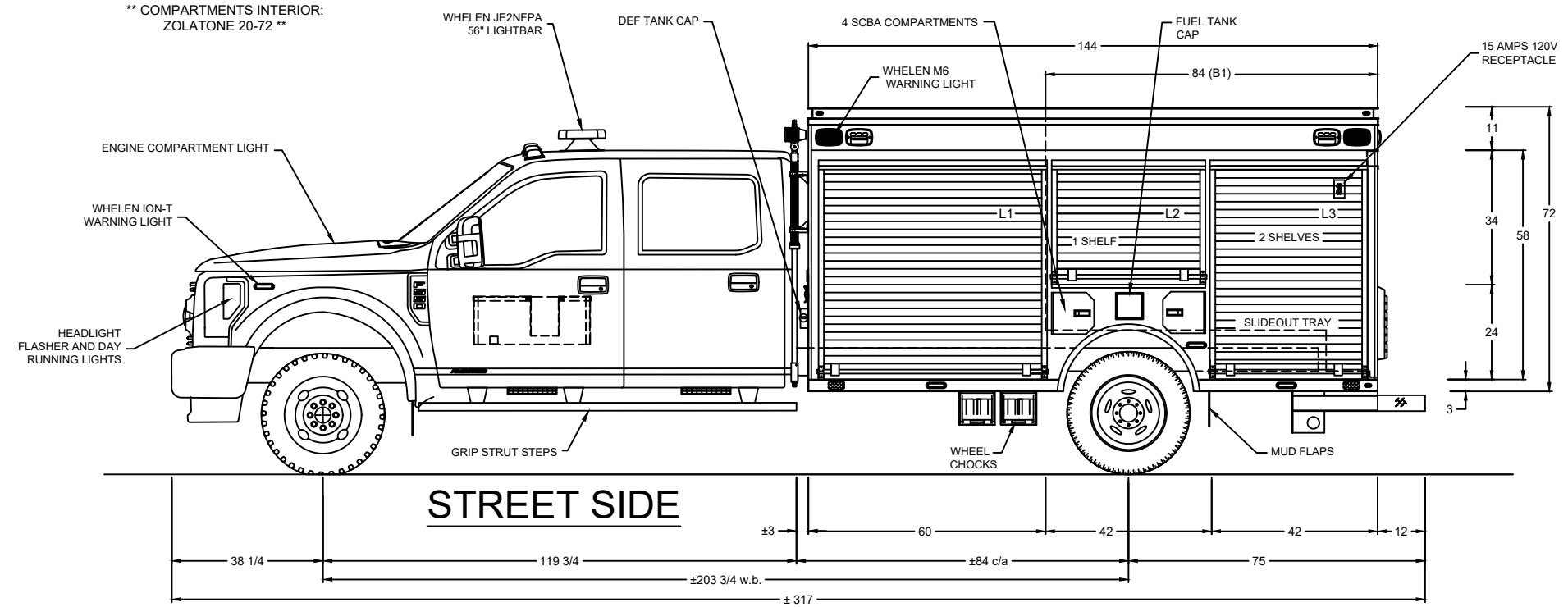

EN CAS DE DISPARITE ENTRE CE DESSIN ET LE DEVIS TECHNIQUE, LE DEVIS TECHNIQUE PREVAUDRA.
 IN CASE OF DISCREPANCY BETWEEN THIS DRAWING AND THE TECHNICAL SPECIFICATIONS, THE TECHNICAL SPECIFICATIONS SHALL PREVAIL.

ZONE	REV.	DESCRIPTION	DATE	APPROVED
2		CORRECTION HITCH CAPACITY	2024-01-08	JM
1		FOLLOWING KICK OFF MEETING	2023-03-16	DB

NAME	DATE	MAXIMETAL Optimized Intervention Vehicles	MAXI-METAL INC. 9345, 25e AVENUE SAINT-GEORGES (QUÉBEC) G6A 1L1
DRAWN BY	2024-04-24		PHONE NO.: 418 228-6637 418 228-MAXI 1 800 510-6637 FAX NO.: 418 228-0493
TYPICAL DIMENSIONS : INCH		CERTIFIED ISO 9001 : 2015	
TOLERANCES (EXCEPT AS SPECIFIED)		TITLE: RESCUE WALK AROUND	
X: ±1/16	X: ±100	DRAWING NO.: ENGINEERING 0016	
XX: ±1/32	XX: ±010	PROJECT:	
X/XX: ±1/64	XXX: ±001	PROPERTY AND CONFIDENTIALITY THE INFORMATION IN THIS DRAWING IS CONFIDENTIAL AND PROPERTY OF MAXI-METAL INC. ANY COPYRIGHT IS PROHIBITED WITHOUT OUR WRITTEN APPROVAL. ©	
ANGLE: ±0.5°		ANSI	SCALE: QUANTITY: